

SAP HANA on VMware vSphere 8.0U2 Based on Scale-up HA840 G3 with Local Boot and Hitachi Virtual Storage Platform

Reference Architecture Guide

© 2024 Hitachi Vantara LLC. All rights reserved.

No part of this publication may be reproduced or transmitted in any form or by any means, electronic or mechanical, including copying and recording, or stored in a database or retrieval system for commercial purposes without the express written permission of Hitachi, Ltd., Hitachi Vantara, Ltd., or Hitachi Vantara Corporation (collectively "Hitachi"). Licensee may make copies of the Materials provided that any such copy is: (i) created as an essential step in utilization of the Software as licensed and is used in no other manner; or (ii) used for archival purposes. Licensee may not make any other copies of the Materials. "Materials" mean text, data, photographs, graphics, audio, video and documents.

Hitachi reserves the right to make changes to this Material at any time without notice and assumes no responsibility for its use. The Materials contain the most current information available at the time of publication.

Some of the features described in the Materials might not be currently available. Refer to the most recent product announcement for information about feature and product availability, or contact Hitachi Vantara LLC at https://support.hitachivantara.com/en_us/contact-us.html.

Notice: Hitachi products and services can be ordered only under the terms and conditions of the applicable Hitachi agreements. The use of Hitachi products is governed by the terms of your agreements with Hitachi Vantara LLC.

By using this software, you agree that you are responsible for:

1. Acquiring the relevant consents as may be required under local privacy laws or otherwise from authorized employees and other individuals; and
2. Verifying that your data continues to be held, retrieved, deleted, or otherwise processed in accordance with relevant laws.

Notice on Export Controls. The technical data and technology inherent in this Document may be subject to U.S. export control laws, including the U.S. Export Administration Act and its associated regulations, and may be subject to export or import regulations in other countries. Reader agrees to comply strictly with all such regulations and acknowledges that Reader has the responsibility to obtain licenses to export, re-export, or import the Document and any Compliant Products.

Hitachi and Lumada are trademarks or registered trademarks of Hitachi, Ltd., in the United States and other countries.

AIX, DB2, DS6000, DS8000, Enterprise Storage Server, eServer, FICON, FlashCopy, GDPS, HyperSwap, IBM, OS/390, PowerHA, PowerPC, S/390, System z9, System z10, Tivoli, z/OS, z9, z10, z13, z14, z15, z16, z/VM, and z/VSE are registered trademarks or trademarks of International Business Machines Corporation.

Active Directory, ActiveX, Bing, Excel, Hyper-V, Internet Explorer, the Internet Explorer logo, Microsoft, Microsoft Edge, the Microsoft corporate logo, the Microsoft Edge logo, MS-DOS, Outlook, PowerPoint, SharePoint, Silverlight, SmartScreen, SQL Server, Visual Basic, Visual C++, Visual Studio, Windows, the Windows logo, Windows Azure, Windows PowerShell, Windows Server, the Windows start button, and Windows Vista are registered trademarks or trademarks of Microsoft Corporation. Microsoft product screen shots are reprinted with permission from Microsoft Corporation.

All other trademarks, service marks, and company names in this document or website are properties of their respective owners.

Copyright and license information for third-party and open source software used in Hitachi Vantara products can be found in the product documentation, at <https://www.hitachivantara.com/en-us/company/legal.html>.

Feedback

Hitachi Vantara welcomes your feedback. Please share your thoughts by sending an email message to SolutionLab@HitachiVantara.com. To assist the routing of this message, use the paper number in the subject and the title of this white paper in the text.

Revision history

Changes	Date
Initial release	September 2024

Reference Architecture Guide

Use this reference architecture guide to design your implementation of Hitachi Solution for the SAP HANA platform using a converged solution for VMware vSphere. This scalable, converged infrastructure uses Hitachi Advanced Server HA840 G3 with a Hitachi storage system certified as SAP HANA enterprise storage. You will see Hitachi Virtual Storage Platform E1090 used in this guide, but you can use other certified storage systems from Hitachi.

SAP HANA tailored datacenter integration (TDI) offers great flexibility for SAP business solutions in production and non-production environments. This can be in bare metal or virtualized environments.

Hitachi Solution for SAP HANA with Intel Xeon scalable processors running on VMware vSphere follows the SAP HANA TDI guidelines. The supported VMware ESXi version for SAP HANA can be found in [SAP Note 2652670](#) (SAP user credentials required). It offers the power of SAP HANA while benefiting from the flexibility of a virtualized environment. It is ready to plug into your network to provide real-time access to operational data inside SAP HANA in your software-defined data center.



Note: Testing of this configuration was in a lab environment. Many factors affect production environments beyond prediction or duplication in a lab environment. Follow the recommended practice of conducting proof-of-concept testing for acceptable results in a non-production, isolated test environment that otherwise matches your production environment before your production implementation of this solution.

Solution overview

This solution uses the Hitachi Advanced Server HA840 G3 installed with NS204i-u device for local boot and directly attached Hitachi Virtual Storage Platform E1090.

Implement and configure VMware following VMware and SAP best practices to guarantee best performance for SAP HANA running on a single or multiple virtual machine deployment.

Hitachi Advanced Server HA840 G3 is certified as a scale-up appliance in various configurations running SUSE Linux Enterprise Server (SLES) for SAP Applications or Red Hat Enterprise Linux (RHEL). For more details, see the [Certified and Supported SAP HANA Hardware Directory](#).

The Hitachi engineering team tested full socket for two VMs installed with SLES and two VMs installed with RHEL.

VMware has certified vSphere 8.0U2 on Intel Sapphire Rapids processors for virtualized SAP HANA deployments. See [SAP Note 3372365](#) (SAP user credentials required).

Solution elements

The converged infrastructure stack of Hitachi Advanced Server for SAP HANA follows the rules of SAP HANA TDI for virtualized environments. Leverage the flexibility of SAP HANA TDI for setups with multiple servers in a single environment using one SAP HANA-certified Hitachi enterprise storage system. This enables consolidated landscapes that guarantee equal performance and reliability as in bare metal appliances.

Hardware elements

This reference architecture guide uses Hitachi Advanced Server HA840 G3 for running VMware vSphere to host SAP HANA. It also uses Hitachi Virtual Storage Platform E1090 as persistent storage, although you can substitute any other members of the VSP E, VSP G, VSP F, VSP 5000, and VSP One Block series certified as SAP HANA Enterprise Storage if you have different needs. For a full list of Hitachi Vantara SAP HANA Enterprise Storage certifications, see <https://www.sap.com/dmc/exp/2014-09-02-hana-hardware/enEN/#/solutions?filters=storage;ve:3&sort=Latest%20Certification&sortDesc=true>.

The following table lists the hardware elements used in this solution.

Hardware	Quantity	Configuration	Role
Hitachi Advanced Server HA840 G3	1	CPU* – 4 Intel Sapphire Rapids 4 Intel Xeon Platinum 8490H Processor 60-core, 1.9GHz, 350W 2 Liquid Cooling FIO Heat Sink Kit	ESXi Host
Internal Drive	1	NS204i-u 2 * M.2 SSD 480 GB	Local disk for ESXi installation
Drive Cage box	2	HPE DL560 Gen11 8SFF TM Kit	Drive cage
PCIe Network cards	2	INT E810 10/25GbE 2p SFP28 Network Adapter	For SAP HANA 10/25 GbE client network and additional 10/25 GbE
	2	Cisco SFP+ 3M Twin axial cables	network
VSP E1090 (used by the Engineering lab)	1	CTL: 1 pair 32 Gbps 4-port CHB: 1 pair MPU: 1 pair Cache: 1024 GB NVMe SSDs:	Block storage

Hardware	Quantity	Configuration	Role
HBA Card	2	HPE SN1610E 32Gb 2p FC PCIe HBA 32 Gbps SFP	Connectivity to the external storage sub-system
Cisco Nexus 92348 switch (Optional)	1	48 x 1 GbE Ports	Optional switch for management network
Cisco Nexus 93180YC-FX/FX3 switch (Optional)	2	48 x 25GbE Ports	Optional switches for client network or additional backup network
Minkel Global Solutions Rack	1	1 standard rack	Optional rack for mounting server/storage/switches
PDUs	6	Vertical PDUs	Optional PDUs for solution

Software components

This solution uses VMware ESXi as a hypervisor. Red Hat Enterprise Linux and SUSE Linux Enterprise Server for SAP Applications are available as guest operating systems within the VMs for running SAP HANA. For more information see the [Hitachi Product Compatibility Guide](#).

The following table lists the software elements used in this solution.

Software	Details
Host operating system	ESXi8.0U2 for host
Virtual machine operating system	SUSE Linux Enterprise Server 15 SP5 for SAP Applications
	Red Hat Enterprise Linux 9.2 for SAP Applications
SAP HANA SPS07 and later	

Solution design

The detailed design of the Hitachi Solution for SAP HANA virtualized (vHANA) using TDI and SAP HANA on ESXi in this reference architecture guide includes the following:

- [Hitachi Advanced Server HA840 G3 configuration \(on page 6\)](#)
- [Network architecture configuration \(on page 7\)](#)

- [Storage architecture \(on page 8\)](#)
- [VMware vSphere configuration \(on page 11\)](#)
- [Guest operating system configuration \(on page 14\)](#)
- [SAP HANA installation and configuration \(on page 14\)](#)

Hitachi Advanced Server HA840 G3 configuration

The following figure shows the back view of Hitachi Advanced Server HA840 G3 (HA840 G3) when using external storage.

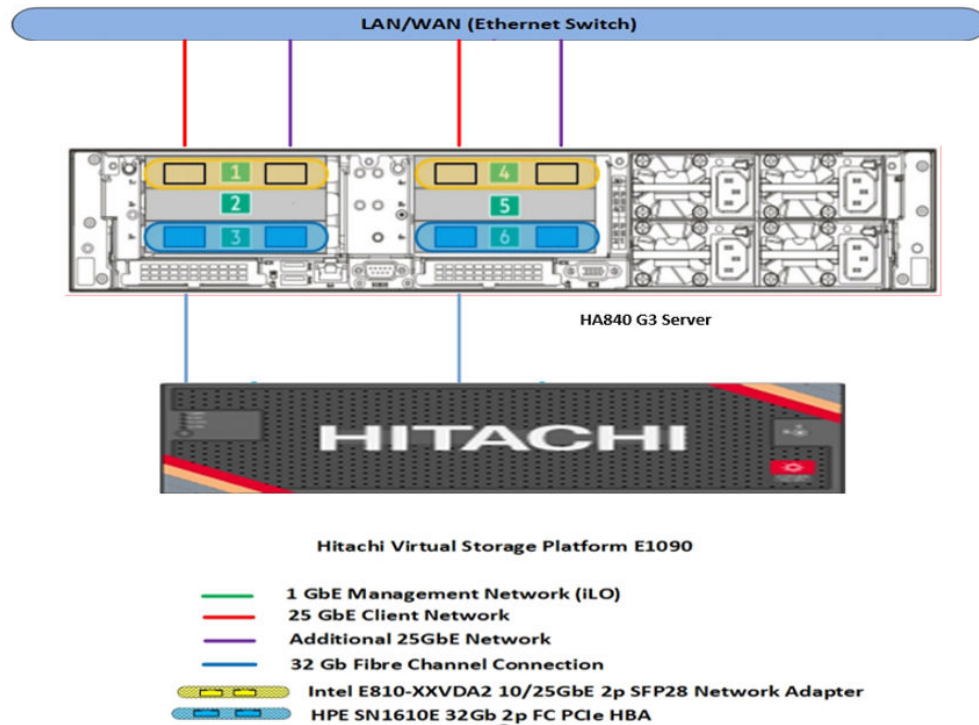

Supported configurations

This solution supports the configurations listed in the following table.

Total RAM per SAP HANA node	512 GB	1024 GB	2048 GB	4096 GB	8192 GB
DDR5 R-DIMM 16 GB memory (2DPC 4800 MTps)	4 × 8 × 16	4 × 16 × 16	—	—	—
DDR5 R-DIMM 32 GB memory (2DPC 4800 MTps)	—	4 × 8 × 32	4 × 16 × 32	—	—

Total RAM per SAP HANA node	512 GB	1024 GB	2048 GB	4096 GB	8192 GB
DDR5 R-DIMM 64 GB memory (2DPC 4800 MTps)	—	—	4 × 8 × 64	4 × 16 × 64	—
DDR5 R-DIMM 128 GB memory (2DPC 4800 MTps)	—	—	—	4 × 8 × 128	4 × 16 × 128

Network architecture configuration

Connect the 1 GbE management port on Hitachi Advanced Server HA840 G3 to a Cisco Nexus 92348, or to any other external 1 GbE switch for management connectivity.

Make the following 25 GbE network connections for the client network setup for ESXi host and virtual machine for uplink network:

- Connect the following to Cisco Nexus 93180YC-FX/FX3 switches or to any other external switches: Port 1 of dual port Intel E810-XXVDA2 2-port 25GbE Network Adapter on PCIe_Slot1.
- Port 1 of dual port Intel E810-XXVDA2 2-port 25 GbE Network Adapter on PCIe_Slot4.
- Configure the corresponding two ports at the VMware ESXi level as uplinks in the virtual standard switch (VSS). Configure both vmnics as active. Use these two ports as the management network for the ESXi node as well as the network for the guest operating system. This acts as the client network for the SAP HANA node.
- At installation, the field engineer from Hitachi Vantara works with your VMware vCenter administrator to convert, merge, and migrate the VSS to your existing or new virtual distributed switch.
- Optional — At this point, to speed up detecting corrupted connections, configure external switch ports with a port channel set to active/active as well as setting the LACP timeout value to short. On VDS, use vLAGs instead of uplinks.

If additional 25 GbE network connections are needed, connect Port 2 of both 25 GbE Intel E810-XXVDA2 PCIe cards to the Cisco Nexus 93180YC-FX/FX3 switches or to any other external switches.

Configure the external switch ports with a short LACP timeout value to speed up detecting corrupted connections.

PCIe Slot 1 and Slot 4 of the primary port as uplinks in the VSS. PCIe Slot 1 and Slot 4 secondary ports (port 2) can be used as you want, such as in the following examples:

- Extra management kernel ports
- Extra virtual machine traffic
- VMware vSphere vMotion

- Backup
- SAP HANA System Replication

The following table provides network setup details.

Network Card	Port	Network Description
PCIe_Slot1#	1	VMware ESXi kernel and virtual machine traffic.
	2	Free for use as additional network for backup, SAP HANA system replication, or other purposes.
PCIe_Slot4#	1	VMware ESXi kernel and virtual machine traffic.
	2	Free for use as an additional network for backup, SAP HANA system replication or other purposes.

Slot_#: See the following figure for the back view of HA840 G3 with PCIe slots.

The following illustration shows PCI cards and the management network connection.

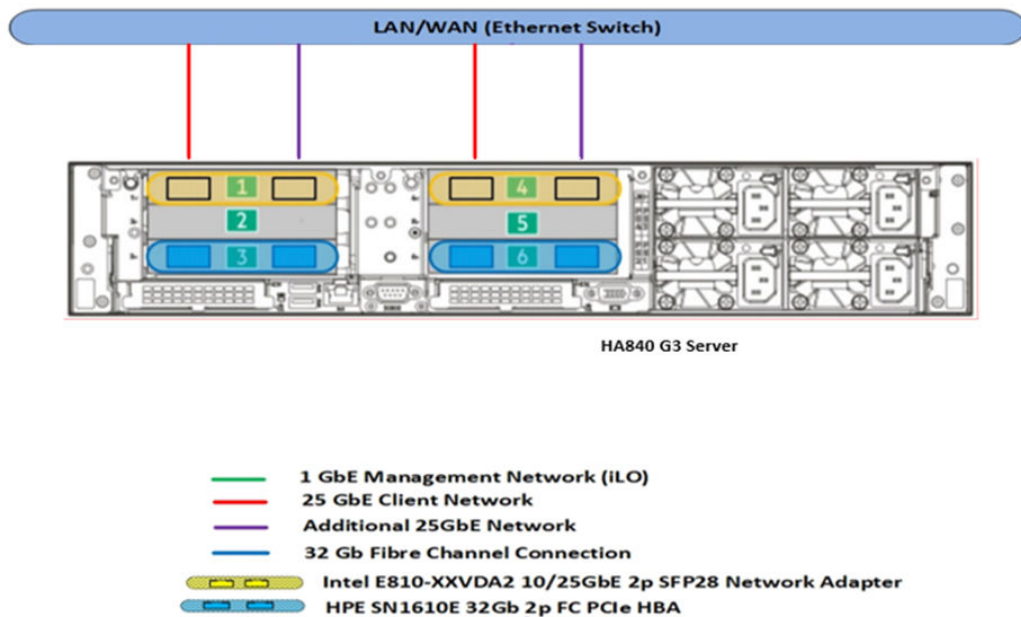

Note: The ESXi kernel network and virtual machine traffic can be on the same network switch or on separate network switches. It depends on the network environment.

Storage architecture

The following storage architecture and configuration was used for this solution:

- [ESXi Operating system boot configuration \(on page 9\)](#)
- [Hitachi Virtual Storage Platform setup and configuration \(on page 9\)](#)

- [Parity Group, RAID, and LUN configuration \(on page 10\)](#)
- [Virtual machine datastore configuration \(on page 11\)](#)

ESXi Operating system boot configuration

This solution configuration requires NS204i-u mirrored M.2 NVMe SSDs for booting. It uses two 480 GB SSDs as RAID 1 mirrored operating system volumes to host the hypervisor.

Hitachi Virtual Storage Platform setup and configuration

For the Hitachi Solution for SAP HANA virtualized (vHANA) using TDI, these are the storage components needed to setup configuration for SAP HANA using Hitachi Virtual Storage Platform (VSP) storage for this solution.

The storage configuration for SAP HANA node needs the following for different sizes:

- Local storage for OS boot.
 - ESXi volume (OS) NS204i-u mirrored M.2 SSD

The following storage components are required to implement a scale-up SAP HANA system with Hitachi Advanced Server HA840 G3 using external storage:

- 2 × HPE SN1610E 32 Gb 2p FC PCIe HBA cards
 - Port 0 of HBA on Primary Riser Slot3
 - Port 1 of HBA on Primary Riser Slot3
 - Port 0 of HBA on Secondary Riser Slot6
 - Port 1 of HBA on Secondary Riser Slot6
- 1 VSP G series/VSP E series storage with storage drive box trays (DBS/DBN)

The following are mandatory for the external storage option with direct connection between Hitachi Virtual Storage Platform and the SN1610E 32 Gb HBA on Hitachi Advanced Server HA840 G3:

- Enable Host Mode Option 02, Host Mode Option 94, and Host Mode Option 109 for the corresponding storage port connected with the server.

Host Mode Option 109 — This option fixes a SAN boot issue, when the system cannot find the Boot LUN after a restart.

Host Mode Option 94 — This option is mandatory for direct connection between the Hitachi Virtual Storage Platform and the SN1610E 32 Gb HBA. If this mode is not set, then SAN storage cannot be identified from the SN1610E 32 Gb HBA.

Host Mode Option 02 (Optional) — This option is recommended when the system uses test-unit-ready (TUR) for path_checker in the `/etc/multipath.conf` file. This mode is typically used for fencing technology.

An example configuration for port properties with Hitachi Virtual Storage Platform is listed in the following table.

For this setting	Use this value
Port Security	Disabled
Port Speed	32 Gbps
Fabric	OFF
Connection Type	P-to-P

Parity Group, RAID, and LUN configuration

This reference architecture uses a dynamic provisioning pool design for the storage layout that ensures maximum utilization and optimization at a lower cost for Hitachi Solution for SAP HANA using VMware vSphere.

This is the configuration of parity groups, RAID level, and LUNs. Use two dynamic provisioning pools with the specific parity groups and LDEV assignment listed in the following table for the storage layout.

Dynamic Provisioning Pool	Parity Group	RAID Level and Disks	LDEV ID	LDEV Size
OS_SH_DATA_Pool	1	RAID 6 (6D+2P) on 1.92 TB SSD drives	00:00:00	2.6 TB
			00:00:01	2.6 TB
			00:00:02	2.6 TB
			00:00:03	2.6 TB
LOG Pool	2	RAID 10(2D+2D) on 1.92 TB SSD drives	00:00:04	1.5 TB
			00:00:05	1.5 TB

This solution uses a dynamic provisioning pool (HDP) design for the storage layout.

Two pools are used to provide storage and throughput for all supported storage sizes:

- NS204i-u mirrored M.2 NVMe SSD is used for ESXi OS boot.
- Pool 0 is used to create virtual volumes (V-Vols) for OS, data and shared binaries of virtual machines. Additional RAID groups and pool volumes can be added to increase the size of Pool 0 to support higher memory configurations.
- Pool 1 is used to create virtual volumes for log of virtual machines.
- Thin provisioning is used to leverage benefits of automatic performance optimization and storage space savings across pools of virtual capacity.

Virtual machine datastore configuration

The ESXi installer from Hitachi Vantara automatically creates datastores during installation, and the following are details of the created datastore example tested in the lab environment.

The following volumes are created on the ESXi host.

```
[root@esxihana:~] df -h
Filesystem      Size  Used Available Use% Mounted on
VMFS-6          319.0G  1.4G   317.6G   0% /vmfs/volumes/esxihana_boot
VMFS-6          499.8G 402.3G   97.4G   81% /vmfs/volumes/HANA_OS_VMFS
VMFS-6          3.0T   1.0T    2.0T   33% /vmfs/volumes/HANA_SHARED_VMFS
VMFS-6          767.8G 257.5G   510.3G   34% /vmfs/volumes/HANA_LOG_VMFS2
VMFS-6          767.8G 257.5G   510.3G   34% /vmfs/volumes/HANA_LOG_VMFS1
VMFS-6          767.8G 257.5G   510.2G   34% /vmfs/volumes/HANA_LOG_VMFS3
VMFS-6          1.5T  309.5G    1.2T   20% /vmfs/volumes/HANA_DATA_VMFS1
VMFS-6          767.8G 257.5G   510.2G   34% /vmfs/volumes/HANA_LOG_VMFS4
VMFS-6          1.5T  309.5G    1.2T   20% /vmfs/volumes/HANA_DATA_VMFS2
VMFS-6          1.5T  309.5G    1.2T   20% /vmfs/volumes/HANA_DATA_VMFS3
VMFS-6          1.5T  309.5G    1.2T   20% /vmfs/volumes/HANA_DATA_VMFS4
VMFSOS          119.8G  22.0G   97.7G   18% /vmfs/volumes/OSDATA-66b666b9-29cb159f-c883-303ea705709a
vfat            4.0G  302.9M   3.7G    7% /vmfs/volumes/BOOTBANK1
vfat            4.0G   64.0K   4.0G    0% /vmfs/volumes/BOOTBANK2
```

The following image shows datastores created for one of the VMs that was used for testing as an example.

Name	Status	Type	Datastore Cluster	Capacity	Free
HANA_DATA_VMFS1	Normal	VMFS 6		1.5 TB	1.2 TB
HANA_DATA_VMFS2	Normal	VMFS 6		1.5 TB	1.2 TB
HANA_DATA_VMFS3	Normal	VMFS 6		1.5 TB	1.2 TB
HANA_DATA_VMFS4	Normal	VMFS 6		1.5 TB	1.2 TB
HANA_LOG_VMFS1	Normal	VMFS 6		767.75 GB	510.33 GB
HANA_LOG_VMFS2	Normal	VMFS 6		767.75 GB	510.33 GB
HANA_LOG_VMFS3	Normal	VMFS 6		767.75 GB	510.33 GB
HANA_LOG_VMFS4	Normal	VMFS 6		767.75 GB	510.33 GB
HANA_OS_VMFS	Warning	VMFS 6		499.75 GB	97.83 GB
HANA_SHARED_VMFS	Normal	VMFS 6		3 TB	2 TB

VMware vSphere configuration

This section covers configuration of the VMware ESXi server, SAP requirements, and possible virtual machine configurations.



Note: The ESXi Side-Channel-Aware Scheduler patch does not allow the use of more than one thread per physical CPU core. This limits the number of vCPUs available on a system. It can impact performance on existing systems and sizing of new systems.

For the SAP HANA workload in the virtual machines, SAP does not allow overcommitting CPU resources. Take this into account when sizing virtual machines and determining the required compute hardware resources.

The following table lists the minimum and maximum sizes for virtual machines running SAP HANA workloads.

Configuration	Size
Minimum virtual machine size	1 socket with at least 120 vCPUs.
Maximum virtual machine size	Depends on CPU architecture
Sub-socket virtual machine sizes	No support for virtual machines with 0.5 socket, 1.5 sockets, 2.5 sockets, and so forth.
Full-socket virtual machine sizes	1 or 2 socket
Maximum number of virtual machines	4 virtual machine 4-socket server (full socket)



Note: Currently half socket (Numa node sharing VM) is not supported for Sapphire Rapid 4-socket servers following [SAP Note 3372365](#).

These are the SAP general sizing guidelines for virtualized environments, with respect to storage, CPU, and memory requirements of SAP HANA.

When creating single or multi-virtual machine environments on a VMware ESXi server, some memory must be reserved for the ESXi server itself. Do not assign all available physical memory to the virtual machines.



Note: According to VMware guidance, this memory overhead can be between 0.5% and a more conservative 3%. For example, on Hitachi Advanced Server HA840 G3 with 2048 GB of RAM, assign up to 1986 GB to virtual machines, after reserving 3% memory for the ESXi host.

ESXi Operating system boot configuration

This solution configuration requires NS204i-u mirrored M.2 NVMe SSD for booting. It uses two 480 GB SSD as RAID 1 mirrored operating system volume to host the hypervisor.

Activate the round robin multipathing policy

Using the round robin multipathing policy allows the configuration of multiple I/O paths between the server and the Hitachi Virtual Storage Platform E series storage system. Round-robin aggregates all physical I/O paths into a single logical path, providing high availability and load balancing for the block devices. The LUNs are always available unless all four paths fail.

Use the round robin multipathing policy for the following I/O paths:

- ESXi operating system on local NVMe SSD
- SAP HANA server operating system LUN
- SAP HANA data volume LUN
- SAP HANA log volume LUN
- SAP HANA shared volume LUN

Virtual machine configuration parameters

VMware releases best practices for configuring the VMware ESXi server when running SAP HANA workloads that result from the certification together with SAP to ensure that all performance requirements for SAP HANA are met.

When provisioning virtual machines for SAP HANA, make sure to use hyperthreads on fewer NUMA nodes instead of only physical CPU cores spread over multiple NUMA nodes.

Also, add or change the parameters on the virtual machines as listed in the following table.

For This	Use This
monitor.halt_in_monitor	TRUE
monitor.idleLoopSpinBeforeHalt	TRUE
tools.guestlib.enableHostinfo	TRUE
numa.nodeAffinity	i.e.: 0,1
disk.EnableUUID	TRUE

Multiple virtual machine configurations

When running this solution in a single-virtual machine configuration, Hitachi Advanced Server HA840 G3 with 4 CPUs provides enough resources to run a virtual machine with the maximum possible 480 vCPUs.

Depending on the number of virtual machines as well as the requirements of the SAP HANA installation inside these virtual machines, further storage resources might be necessary. Contact your Hitachi Vantara account team to size storage for all SAP HANA-certified enterprise storage units.

Sizing is available for SSD drives, and Hitachi Accelerated Flash devices for the maximum number of SAP HANA nodes in the [SAP HANA Certified Hardware Directory](#). For virtualized environments, one virtual machine counts as one SAP HANA node, according to SAP requirements.

In a single server environment, the maximum number of virtual machines is 4 when using only 1-socket virtual machines on 4-socket server. However, this sizing is also valid for running multiple ESXi servers connected to one Hitachi storage system.

SAP HANA Tailored Data Center Integration on Hitachi Virtual Storage Platform E990 and E1090 with Hitachi Storage Virtualization Operating System RF (PDF) at <https://docs.hitachivantara.com/v/u/en-us/application-optimized-solutions/mk-sl-197> provides insight into best practices for Hitachi storage in SAP HANA TDI environments.

According to [SAP Note 3372365](#), Sub NUMA Clustering (SNC-2) is not supported on 4-socket hosts.

Guest operating system configuration

The following are supported as guest operating systems for the virtual machines in Hitachi Advanced Server HA840 G3:

- SUSE Linux Enterprise Server for SAP Applications
- Red Hat Enterprise Linux

Changing the configuration settings is only supported according to the guidelines from SAP and the operating system distributor. Otherwise, changes can cause significant performance problems. The following SAP Notes for SUSE Linux Enterprise Server and Red Hat Enterprise Linux are a good starting point for information on this topic:

- [1944799 - SAP HANA Guidelines for SLES Operating System Installation](#)
- [2684254 - SAP HANA DB: Recommended OS settings for SLES 15 / SLES for SAP Applications 15](#)
- [2009879 - SAP HANA Guidelines for Red Hat Enterprise Linux \(RHEL\) Operating System](#)
- [2235581 – SAP HANA: Supported Operating System](#)

The initially delivered configuration of the operating system should persist. Do not make any modifications to the operating system, except as noted or approved by SAP.

SAP HANA installation and configuration

This section describes the SAP HANA configuration on the scale-up configuration for Hitachi Solution the SAP HANA on VMware vSphere.

SAP HANA volume configuration for virtual machines

Use the following LDEVs and DP-VOLs for the SAP HANA virtual machine configuration on the Hitachi Virtual Storage Platform system; we configure the following for the engineering testing environment as an example:

- Four 2.6 TB LDEVs to create the following:
 - Four 2048 GB DP-VOLs as VMFSs for SAP HANA data volumes
 - One 1.5 TB DP-VOLs as VMFS for SAP HANA shared volume
 - One 500 GB DP-VOL as VMFS to create OS volume
- Four 768 GB DP-VOLs to create four 768 GB VMFSs for SAP HANA log volumes

The logical volume manager (LVM) configures the SAP HANA persistent storage volumes from virtual machines. With four VMDKs for the SAP HANA log, the LVM creates a single 4-way striped volume on which to create the XFS file system to store the SAP HANA log volumes. Similarly, configure this for the SAP HANA data volumes.

For SAP HANA shared, create an XFS file system to store SAP HANA binaries, configuration, and trace files.

SAP HANA software installation

After configuring the file system for the SAP HANA data volume and log volume, install the latest SAP HANA Datacenter Service Point (DSP) stack on the SAP HANA server, upgraded to the required SAP HANA revision.

Install the following SAP HANA software components on the SAP HANA node for VMware vSphere server:

- SAP HANA database
- SAP HANA client
- SAP Host agent

Engineering validation

The test methodology for validating the SAP HANA TDI Enterprise Storage configuration with Hitachi Virtual Storage Platform E1090 and ESXi8.0U2 used the following.

For TDI solutions, SAP HANA Hardware, and Cloud Measurement Tool (HCMT) revision hcmt-078_00 was tested on the following volumes for RHEL 9.2:

- Data volume
- Log volume
- Shared volume

For TDI solutions, SAP HANA Hardware, and Cloud Measurement Tool (HCMT) revision hcmt-078_00 was tested on the following volumes for SLES 15SP5:

- Data volume
- Log volume
- Shared volume

For optimal use of the system with a SAP HANA database, use the parameters listed in the corresponding appendix for your operating system release. Follow SAP Note 2399079 to set up these parameters defined in the `global.ini` file for SAP HANA 2.0.

Sample global.ini files

This section provides the `global.ini` files used for the following operating systems.

Red Hat Enterprise Linux 9.2 operating system

Use this `global.ini` configuration file with a solution using Red Hat Enterprise Linux 9.2 for an operating system.

```
# global.ini last modified 2023-12-07 11:22:57.355173 by hdbnameserver
[communication]
tcp_backlog = 2048

[fileio]
async_read_submit[log] = on
```

```

async_write_submit_active[log] = on
async_write_submit_blocks[log] = all
min_submit_batch_size[log] = 16
max_submit_batch_size[log] = 64
max_parallel_io_requests[log] = 128
size_kernel_io_queue[log] = 512
async_read_submit[data] = on
async_write_submit_active[data] = on
async_write_submit_blocks[data] = all
min_submit_batch_size[data] = 16
max_submit_batch_size[data] = 64
max_parallel_io_requests[data] = 128
size_kernel_io_queue[data] = 512

[multidb]
mode = multidb
database_isolation = low
singletenant = yes

[persistence]
basepath_datavolumes = /hana/data/HIT
basepath_logvolumes = /hana/log/HIT

```

SUSE Enterprise Linux 15 SP5 operating system

Use this `global.ini` configuration file with a solution using SUSE Enterprise Linux 15 SP5 operating system for an operating system.

```

# global.ini last modified 2023-12-10 15:39:24.549725 by hdbnameserver
[communication]
tcp_backlog = 2048
[database_initial_encryption]
backup_encryption = on
persistence_encryption = on
log_encryption = on
[fileio]
async_read_submit[log] = on
async_write_submit_active[log] = on
async_write_submit_blocks[log] = all
min_submit_batch_size[log] = 16
max_submit_batch_size[log] = 64
max_parallel_io_requests[log] = 128
size_kernel_io_queue[log] = 512
async_read_submit[data] = on
async_write_submit_active[data] = on
async_write_submit_blocks[data] = all
min_submit_batch_size[data] = 16
max_submit_batch_size[data] = 64
max_parallel_io_requests[data] = 128
size_kernel_io_queue[data] = 512

[multidb]

```



```

mode = multiddb
database_isolation = low
singletenant = yes

[persistence]
basepath_datavolumes = /hana/data/HIT
basepath_logvolumes = /hana/log/HIT

```

Product descriptions

The following products are part of this solution.

Hitachi Advanced Server HA840 G3

The [Hitachi Advanced Server HA840 G3](#) is a high-density, four-socket (4S) server with high performance, scalability, and reliability, all in a 2U chassis. Supporting the latest [4th Generation Intel Xeon Scalable Processors](#), the Hitachi Advanced Server HA840 G3 offers greater processing power, up to 8 TB of DDR5 memory, IO up to six PCIe Gen 5 slots, 2 OCP slots, plus the intelligence and simplicity of automated management with iLO 6. The Hitachi Advanced Server HA840 G3 is the ideal server for business-critical workloads, in-memory databases, data analytics, virtualization, server consolidation, business processing, and general 4S data-intensive applications where data center space and the right performance are paramount.

Optimized for performance, high density, and power efficiency in a dual-processor server, [HA800 G3 series servers](#) deliver a balance of compute and storage capacity. These rack mounted servers have the flexibility to power a wide range of solutions and applications.

The highly scalable memory supports up to 16 TB RAM using 64 slots of 4800 MHz DDR5 RDIMM. HA840 G3 is powered by the Intel Xeon scalable processor family for complex and demanding workloads. Flexible OCP and PCIe I/O expansion card options are available.

The following applications were installed in individual virtual machines in this architecture and would be used in most cases:

- vCenter Server
- Hitachi Ops Center

Other management applications can be installed on additional virtual machines depending on customer needs and requirements.

Hitachi Virtual Storage Platform E1090

The Hitachi Virtual Storage Platform E1090 (VSP E1090) storage system is a high-performance, large-capacity data storage system. The VSP E1090 all-flash arrays (AFAs) support NVMe and SAS solid-state drives (SSDs). The VSP E1090H hybrid models can be configured with both SSDs and hard disk drives (HDDs).

- The NVMe flash architecture delivers consistent, low-microsecond latency, which reduces the transaction costs of latency-critical applications and delivers predictable performance to optimize storage resources.
- The hybrid architecture allows for greater scalability and provides data-in-place migration support.

SAP HANA

SAP HANA converges database and application platform capabilities in-memory to transform transactions, analytics, text analysis, predictive and spatial processing so businesses can operate in real-time. This combines database, data processing, and application platform capabilities in a single in-memory platform. Also, the platform provides libraries for predictive, planning, text processing, spatial, and business analytics — all on the same architecture. This architecture comes from leading hardware partners of SAP, including Hitachi Vantara.

By eliminating the divide between transactions and analytics, SAP HANA allows you to answer any business question anywhere in real time.

As an SAP customer, you can [download more information](#), including the following:

- SAP HANA Master Guide

This is the central starting point for the technical implementation of SAP HANA. Use this guide for basic concepts and for planning.

- SAP HANA Server Installation and Update Guide

This guide provides an overview of how to install and update an SAP HANA system with the SAP HANA lifecycle management tools.

- SAP HANA Administration Guide

This guide explains how to configure, manage, maintain, and optimize your SAP HANA installation using SAP HANA administration tools.

[SAP HANA hardware directory](#) provides information about SAP HANA appliances certified by SAP hardware partners.

SAP HANA Tailored Data Center Integration

SAP increases flexibility and provides an alternative to SAP HANA Appliances with SAP HANA tailored data center integration (TDI) in currently 5 phases. This includes many kinds of virtualization technology. Understanding the possibilities and requirements of an SAP HANA TDI environment is crucial. One of these requirements is that all virtualized environments for SAP HANA are considered as SAP HANA TDI by SAP. SAP provides documentation around SAP HANA TDI environments that explain the 5 phases of SAP HANA TDI as well as hardware and software requirements for the whole stack:

- [SAP Help Portal: SAP HANA Platform](#) (frequently asked questions)
- [SAP HANA Storage Requirements](#)
- [SAP HANA Network Requirements](#)

Taking all this into account, Hitachi offers a solution for the whole SAP HANA TDI stack from hardware infrastructure to software deployment.

Operating system options for SAP HANA

SUSE Linux Enterprise Server for SAP Applications and Red Hat Enterprise Linux for SAP HANA are available operating systems when running SAP HANA.

- SUSE Linux Enterprise Server (SLES) for SAP Applications

Compete more effectively through improved uptime, better efficiency, and accelerated innovation using [SUSE Linux Enterprise Server for SAP Applications](#). This is a versatile server operating system for efficiently deploying highly available enterprise-class IT services in mixed IT environments with performance and reduced risk.

SUSE Linux Enterprise Server was the first Linux operating system to be certified for use with SAP HANA. It remains the operating system of choice for most SAP HANA customers.

- Red Hat Enterprise Linux (RHEL) for SAP HANA

Using the stability and flexibility of [Red Hat Enterprise Linux for SAP HANA](#), reallocate your resources towards meeting the next challenges instead of maintaining the status quo. Deliver meaningful business results by providing exceptional reliability and military-grade security. Use Enterprise Linux to tailor your infrastructure as markets shift and technologies evolve.

Changing the configuration settings is only supported along the guidelines of SAP and the operating system distributor and may otherwise cause significant performance problems. The following SAP Notes for SUSE Linux Enterprise Server and Red Hat Enterprise Linux are a good starting point for information on this topic:

- [1944799 - SAP HANA Guidelines for SLES Operating System Installation](#)
- [2009879 - SAP HANA Guidelines for Red Hat Enterprise Linux \(RHEL\)](#)

For more details, see "Updating and Patching the Operating System" by searching in the "View SAP HANA document" from [Technical Information and Best Practices](#).

VMware vSphere

VMware vSphere is a virtualization platform that provides a datacenter infrastructure. It helps you get the best performance, availability, and efficiency from your infrastructure and applications. Virtualize applications with confidence using consistent management.

VMware vSphere has the following components:

- VMware vSphere ESXi

This hypervisor loads directly on a physical server. ESXi provides a robust, high-performance virtualization layer that abstracts server hardware resources and makes them shareable by multiple virtual machines.

- VMware vCenter Server

This management software provides a centralized platform for managing your VMware vSphere environments so you can automate and deliver a virtual infrastructure with confidence:

- VMware vSphere vMotion
- VMware vSphere Storage vMotion
- VMware vSphere Distributed Resource Scheduler
- VMware vSphere High Availability
- VMware vSphere Fault Tolerance

- VMware vSAN Server

VMware vSAN is VMware's software-defined storage solution for hyperconverged infrastructure, a software-driven architecture that delivers tightly integrated computing, networking, and shared storage from x86 servers. vSAN delivers high performance and highly resilient shared storage by clustering server-attached flash devices and hard disks (HDDs).

vSAN delivers enterprise-class storage services for virtualized production environments along with predictable scalability and All-Flash performance, all at a fraction of the price of traditional, purpose-built storage systems. Just like vSphere, vSAN provides users the flexibility and control to choose from a wide range of hardware options and easily deploy and manage it for a variety of IT workloads and use cases.

Hitachi Vantara

Corporate Headquarters
2535 Augustine Drive
Santa Clara, CA 95054 USA



HitachiVantara.com/contact